

**PAM0102S2 N-Channel MOSFET**

$V_{(BR)DSS}$	$R_{DS(on)MAX}$	$I_D$
110V	234mΩ@10V	2A
	267mΩ@6V	
	278mΩ@4.5V	

**Features**

- ◆ TrenchFET Power MOSFET
- ◆ Low  $R_{DS(ON)}$
- ◆ Surface Mount Package

**Applications**

- ◆ LED Backlighting in LCD TVs
- ◆ DC/DC Converter
- ◆ Load Switch

**Dimensions and Pin Configuration**

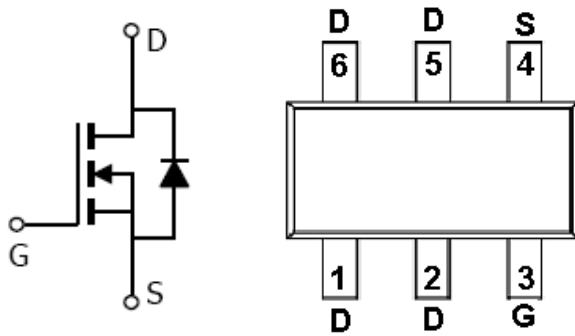

Circuit and Pin Schematic

**Marking Information**

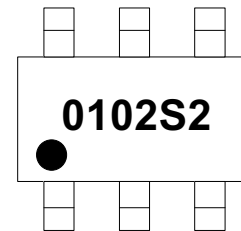

0102S2 = Device Marking Code  
Dot denotes Pin1

**Absolute Maximum Ratings ( $T_A=25^{\circ}C$  unless otherwise specified)**

Parameter	Symbol	Value	Unit
Drain-Source Voltage	$V_{DS}$	110	V
Gate-Source Voltage	$V_{GS}$	±20	V
Continuous Drain Current	$I_D$	2	A
Pulsed Drain Current	$I_{DM}^*$	8	A
Thermal Resistance from Junction to Ambient	$R_{\theta JA}$	357	$^{\circ}C/W$
Junction Temperature	$T_J$	150	$^{\circ}C$
Storage Temperature	$T_{STG}$	-55~+150	$^{\circ}C$
Lead Temperature for Soldering Purposes(1/8" from case for 10 s)	$T_L$	260	$^{\circ}C$

\*Repetitive rating: Pluse width limited by junction temperature.

**Electrical Characteristics ( $T_A=25^\circ\text{C}$  unless otherwise specified)**

Parameter	Symbol	Test Con			Max	
<b>STATIC PARAMETERS</b>						
Drain-source breakdown voltage	$V_{(BR)DSS}$	$V_{GS} = 0V, I_D = 250\mu A$	110			V
Zero gate voltage drain current	$I_{DSS}$	$V_{DS} = 100V, V_{GS} = 0V$			1	$\mu A$
Gate-body leakage current	$I_{GSS}$	$V_{GS} = \pm 20V, V_{DS} = 0V$			$\pm 100$	nA
Gate threshold voltage(note 1)	$V_{GS(th)}$	$V_{DS} = V_{GS}, I_D = 250\mu A$	1.2		2.8	V
Drain-source on-resistance (note 1)	$R_{DS(on)}$	$V_{GS} = 10V, I_D = 1.5A$			234	m $\Omega$
		$V_{GS} = 6V, I_D = 1A$			267	m $\Omega$
		$V_{GS} = 4.5V, I_D = 0.5A$			278	m $\Omega$
Forward tranconductance (note 1)	$g_{FS}$	$V_{DS} = 20V, I_D = 1.5A$		2		S
Diode forward voltage (note 1)	$V_{SD}$	$I_S = 1.3A, V_{GS} = 0V$			1.2	V
<b>DYNAMIC PARAMETERS (note2)</b>						
Input Capacitance	$C_{iss}$	$V_{DS} = 50V, V_{GS} = 0V, f = 1MHz$		190		pF
Output Capacitance	$C_{oss}$			22		pF
Reverse Transfer Capacitance	$C_{rss}$			13		pF
Gate Resistance	$R_g$	$F = 1MHz$	0.3		2.8	$\Omega$
<b>SWITCHING PARAMETERS (note 2)</b>						
Turn-on delay time	$t_{d(on)}$	$V_{DD} = 50V, V_{GEN} = 4.5V$ $R_L = 39\Omega, R_G = 1\Omega, I_D = 1.3A$			45	ns
Turn-on rise time	$t_r$				39	ns
Turn-off delay time	$t_{d(off)}$				26	ns
Turn-off fall time	$t_f$				20	ns
Total Gate Charge	$Q_g$	$V_{DS} = 50V, V_{GS} = 4.5V, I_D = 1.6A$			5.8	nC
Gate-Source Charge	$Q_{gs}$			0.75		nC
Gate-Drain Charge	$Q_{gd}$			1.4		nC

- Notes :**
1. Pulse Test : Pulse width  $\leq 300\mu s$ , duty cycle  $\leq 0.5\%$ .
  2. Guaranteed by design, not subject to production testing.

**Typical Performance Characteristics (TA=25°C unless otherwise Specified)**

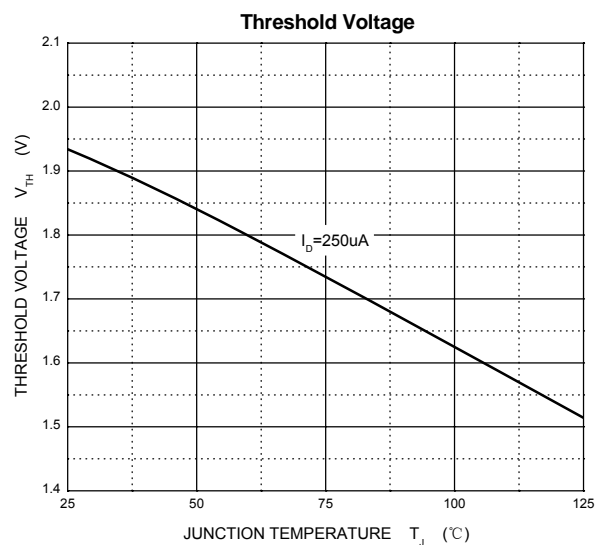
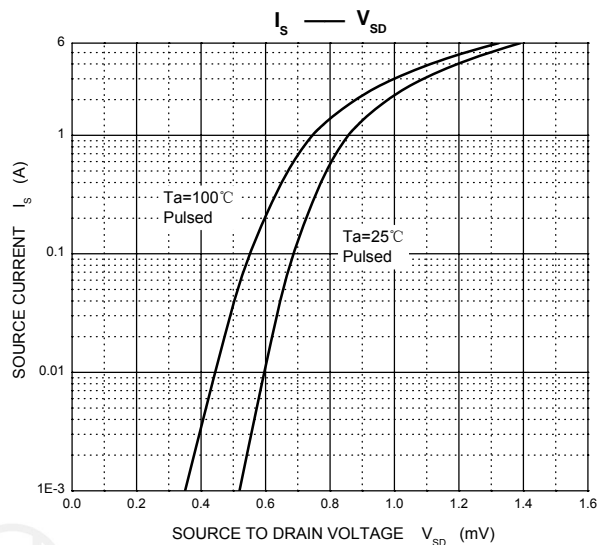
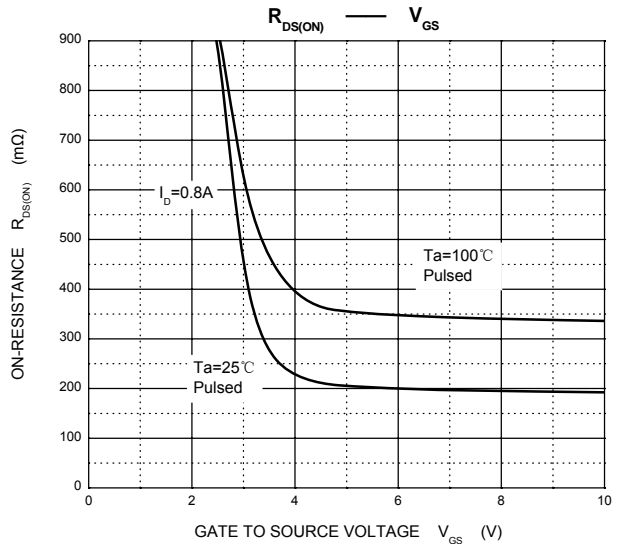
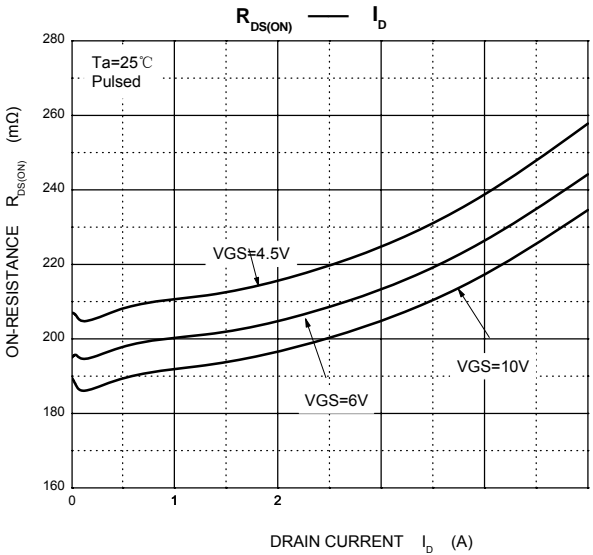
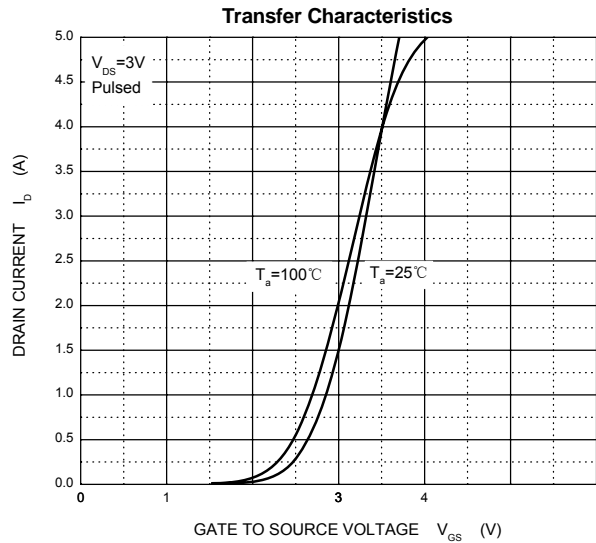
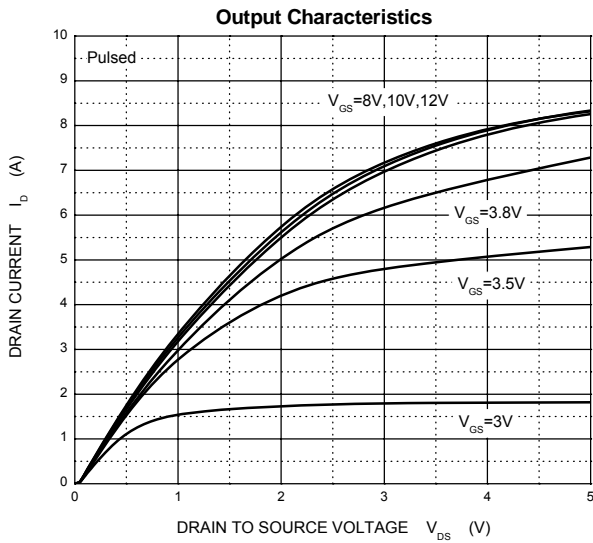

### SOT23-6 Package Outline Drawing

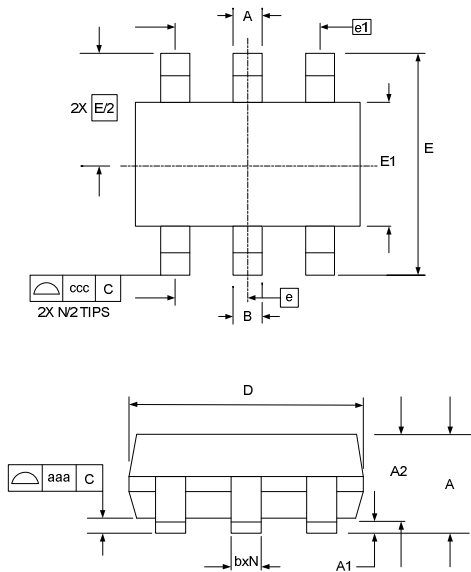

SYM	DIMENSIONS					
	MILLIMETERS			INCHES		
	MIN	NOM	MAX	MIN	NOM	MAX
A	0.90		1.45	0.035		0.057
A1	0.00		0.15	0.000		0.006
A2	0.90	1.15	1.30	0.035	0.045	0.051
b	0.25		0.50	0.010		0.020
c	0.08		0.22	0.003		0.009
D	2.80	2.90	3.10	0.110	0.114	0.122
E1	1.50	1.60	1.75	0.060	0.063	0.069
E	2.80 BSC			0.110 BSC		
e	0.95 BSC			0.037 BSC		
e1	1.90 BSC			0.075 BSC		
N	6			6		
aaa	0.10			0.004		
ccc	0.20			0.008		

### Suggested Land Pattern

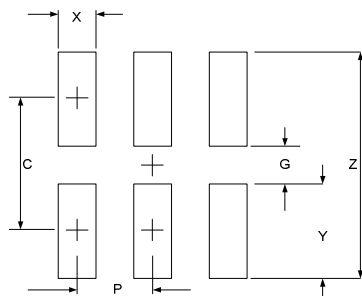

SYM	DIMENSIONS	
	MILLIMETERS	INCHES
C	2.50	0.098
G	1.40	0.055
P	0.95	0.037
X	0.60	0.024
Y	1.10	0.043
Z	3.60	0.141

### Contact Information

Changzhou D-first Electronics CO.,Ltd.

www.first-electronic.com

Email: xhf@first-electronic.cn

Phone: +86 (0519) -8817 1671